

API KIRK CONTAINERS

6 GALLON SAMSON STACKER

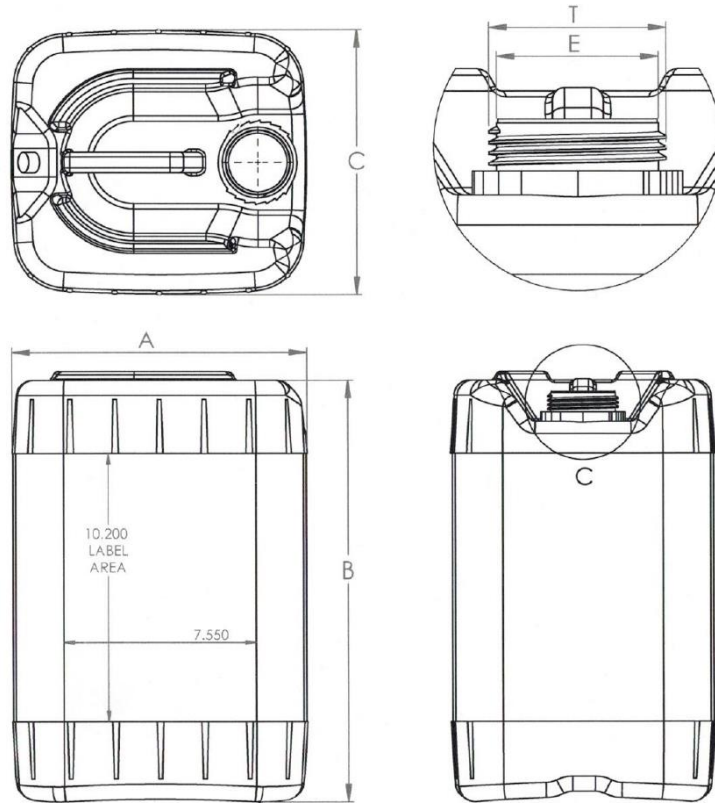

| | |
|------------------|---------------------|
| Mold | 176 |
| Material | HDPE - FDA APPROVED |
| Height | 16.15" |
| Length | 11.75" |
| Width | 10.10" |
| Neck Finish | 70 mm |
| Weight | 3.52 lbs / 1600 gr |
| Pallet Dimension | 48 x 48 x 101 |
| Shipping Units | 120 |
| Pallet Weight | 473 lbs |



+1 (323) 888-1077
 info@apikirkcontainers.com
 www.apikirkcontainers.com

For UN compliance, please refer to our UN testing certification and closing instructions. Available upon request.

All measurements are approximate and subject to change.